

PSSu E F 4DI(-T)(-R)



Decentralised system PSSuniversal I/O

This document is a translation of the original document.

All rights to this documentation are reserved by Pilz GmbH & Co. KG. Copies may be made for internal purposes.

Suggestions and comments for improving this documentation will be gratefully received.

Pilz[®], PIT[®], PMI[®], PNOZ[®], Primo[®], PSEN[®], PSS[®], PVIS[®], SafetyBUS p[®], SafetyEYE[®], SafetyNET p[®], the spirit of safety[®] are registered and protected trademarks of Pilz GmbH & Co. KG in some countries.



SD means Secure Digital.

Contents		Page
Chapter 1 Introduction		
1.1	Validity of documentation	1-1
1.1.1	Retaining the documentation	1-1
1.1.2	Terminology: System environment A and B	1-1
1.2	Overview of documentation	1-2
1.3	Definition of symbols	1-3
Chapter 2 Overview		
2.1	Module structure	2-1
2.1.1	Module features	2-1
2.2	Front view	2-2
Chapter 3 Safety		
3.1	Intended use	3-1
3.2	Safety regulations	3-3
3.2.1	Use of qualified personnel	3-3
3.2.2	Warranty and liability	3-3
3.2.3	Disposal	3-3
Chapter 4 Function description		
4.1	Module features	4-1
4.1.1	Functions	4-1
4.1.2	Integrated protection mechanisms	4-2
4.1.3	Reaction times	4-2
4.2	Configuration	4-3
4.2.1	PSSu assignment in system environment A	4-3
4.2.1.1	Addresses in the process image	4-3
4.2.2	PSSu assignment in system environment B	4-4
Chapter 5 Installation		
5.1	General installation guidelines	5-1
5.1.1	Dimensions	5-1
5.2	Installing the base module	5-3
5.3	Inserting and removing an electronic module	5-4
5.3.1	Inserting an electronic module	5-4
5.3.2	Removing an electronic module	5-5
5.3.3	Changing an electronic module during operation	5-6

Chapter 6 Wiring

6.1	General wiring guidelines	6-1
6.1.1	Mechanical connection of the base modules	6-1
6.2	Terminal configuration	6-3
6.3	Connecting the module	6-4

Chapter 7 Operation

7.1	Messages	7-1
7.2	Display elements	7-2
7.2.1	Display elements for module diagnostics	7-2
7.2.2	Display elements for input status	7-3

Chapter 8 Technical details

8.1	Technical details	8-1
8.2	Order reference	8-4

1.1 Validity of documentation

This documentation is valid for the products types **PSSu E F 4DI**, **PSSu E F 4DI-T** and **PSSu E F 4DI-R**. It is valid until new documentation is published.

This operating manual explains the function and operation, describes the installation and provides guidelines on how to connect the product .

1.1.1 Retaining the documentation

This documentation is intended for instruction and should be retained for future reference.

1.1.2 Terminology: System environment A and B

The PSSu system can be used in two different system environments. The module's application area is described in the chapter "Intended Use" of the manual.

The distinction is made between

- ▶ PSSu in system environment A
- ▶ PSSu in system environment B

The distinction is based on the application area of the PSSu system.

PSSu in system environment A may be used in the

- ▶ Decentralised system PSSu I/O with SafetyBUS p
- ▶ Decentralised system PSSu I/O with ST fieldbuses such as CANopen, DeviceNet
- ▶ **Not** in the automation system PSS 4000

PSSu in system environment B may be used in the

- ▶ Automation system PSS 4000, e.g. with the
 - Decentralised system PSSu I/O with SafetyNET p
 - Control system PSSu PLC
 - Control system PSSu multi

1.2 Overview of documentation

1 Introduction

The introduction is designed to familiarise you with the contents, structure and specific order of this manual.

2 Overview

This chapter provides information on the product's most important features.

3 Safety

This chapter must be read as it contains important information on safety and intended use.

4 Function Description

This chapter describes the product's individual components.

5 Installation

This chapter explains how to install the product.

6 Wiring

This chapter describes the product's wiring.

7 Operation

This chapter explains the display elements and advises on what to do if a fault occurs.

8 Technical Details

This chapter contains the product's technical details and order reference.

1.3 Definition of symbols

Information that is particularly important is identified as follows:



DANGER!

This warning must be heeded! It warns of a hazardous situation that poses an immediate threat of serious injury and death and indicates preventive measures that can be taken.



WARNING!

This warning must be heeded! It warns of a hazardous situation that could lead to serious injury and death and indicates preventive measures that can be taken.



CAUTION!

This refers to a hazard that can lead to a less serious or minor injury plus material damage, and also provides information on preventive measures that can be taken.



NOTICE

This describes a situation in which the unit(s) could be damaged and also provides information on preventive measures that can be taken. It also highlights areas within the text that are of particular importance.



INFORMATION

This gives advice on applications and provides information on special features.

1 Introduction

2.1 Module structure

A module consists of

- ▶ Electronic module and
- ▶ Base module with
 - Screw terminals or
 - Cage clamp terminals

The base modules are the carrier units for the electronic modules and are used to connect the field wiring. The electronic modules are inserted on to the base modules and determine the module's function.

Details of the base modules that can be used are available in the chapter entitled “Intended Use”.

2.1.1 Module features

The product has the following features:

- ▶ **4** Digital inputs
- ▶ **2** Test pulse outputs, with the option to configure them as:
 - Independent test pulse outputs that use different test pulses (periphery supply)
 - Outputs with constant voltage (periphery supply)
- ▶ LEDs for:
 - Switch status of each input
 - Module error
- ▶ For failsafe applications in system environment A and B
- ▶ T-type:
 - PSSu E F 4DI-T**: for increased environmental requirements
- ▶ R-type:
 - PSSu E F 4DI-R**: for railway applications

2.2 Front view

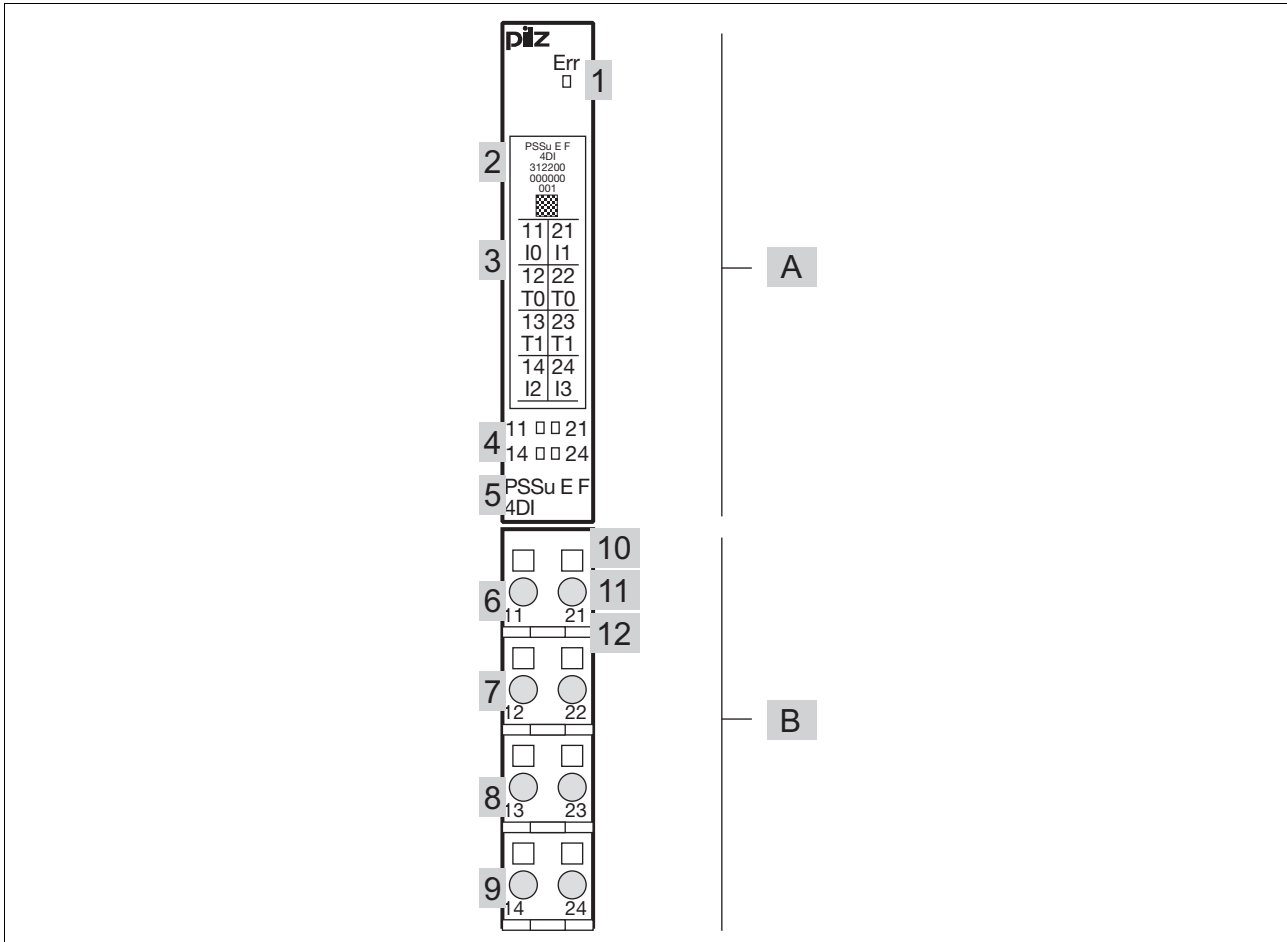

Legend:

- ▶ A: Electronic module
- ▶ B: Base module
- ▶ 1: LED for module diagnostics
- ▶ 2: Labelling strip with:
 - Name of electronic module
 - Order Number
 - Serial number
 - Hardware version number
 - 2D code
- ▶ 3: Labelling strip for the terminal configuration on the base module
- ▶ 4: Status LEDs
- ▶ 5: Name of electronic module
- ▶ 6: Connection level 1
- ▶ 7: Connection level 2
- ▶ 8: Connection level 3
- ▶ 9: Connection level 4

2.2 Front view

- ▶ 10: Square mounting holes (connection levels 1, 2, 3 and 4)
 - With screw to loosen/tighten the screw terminal on base modules with screw terminals
 - With mechanism to operate the cage clamp on base modules with cage clamp terminals
- ▶ 11: Round connection holes (connection levels 1, 2, 3 and 4) for connecting the signal lines
- ▶ 12: Mounting slot for colour marker to label the connection level (connection levels 1, 2, 3 and 4)

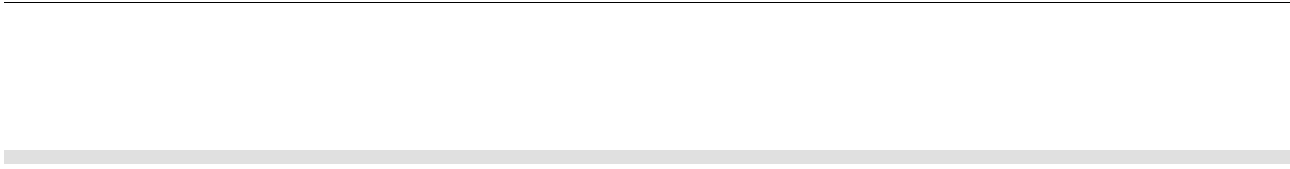

3.1 Intended use

The module may be used for failsafe applications in system environment A and B (automation system PSS 4000).

The module meets the requirements of EN IEC 61508 up to **SIL3** and EN 954-1 up to Category **4**.

It provides type 1 failsafe inputs in accordance with IEC 61131-2.

The module **PSSu E F 4DI-T** is suitable for use where there are increased environmental requirements (see Technical Details).

The module **PSSu E F 4DI-R** is suitable for use where there are increased environmental requirements demanded by railway applications (see Technical Details).

Intended use includes making the electrical installation EMC-compliant. Please refer to the guidelines stated in the "PSSuniversal Installation Manual". The module is designed for use in an industrial environment. It is not suitable for use in a domestic environment, as this can lead to interference.

The following is deemed improper use in particular:

- ▶ Any component, technical or electrical modification to the module
- ▶ Use of the module outside the areas described in this manual
- ▶ Use of the module outside the technical details (see chapter entitled "Technical Details")



INFORMATION

The module is supported by

- ▶ PSSuniversal Configurator and PSSuniversal Assistant from Version 1.4.0 (base type, T-type)
- ▶ PAS4000 from Version 1.1.1 (base type, T-type)
- ▶ PAS4000 from Version 1.5.0 (R-type)
 - We recommend that you always use the latest version (download from www.pilz.de).

3.1 Intended use

The **PSSu E F 4DI** module may be used in conjunction with the following base modules:

- ▶ PSSu BP 1/8S
- ▶ PSSu BP 1/8C
- ▶ PSSu BP 1/12S
- ▶ PSSu BP 1/12C
- ▶ PSSu BP-C1 1/12S
- ▶ PSSu BP-C1 1/12C

The **PSSu E F 4DI-T** and **PSSu E F 4DI-R** modules may be used in conjunction with the following base modules:

- ▶ PSSu BP 1/8S-T
- ▶ PSSu BP 1/8C-T
- ▶ PSSu BP 1/12S-T
- ▶ PSSu BP 1/12C-T
- ▶ PSSu BP-C1 1/12S-T
- ▶ PSSu BP-C1 1/12C-T

3.2 Safety regulations

3.2.1 Use of qualified personnel

The products may only be assembled, installed, programmed, commissioned, operated, maintained and decommissioned by competent persons.

A competent person is someone who, because of their training, experience and current professional activity, has the specialist knowledge required to test, assess and operate the work equipment, devices, systems, plant and machinery in accordance with the general standards and guidelines for safety technology.

It is the company's responsibility only to employ personnel who:

- ▶ Are familiar with the basic regulations concerning health and safety / accident prevention
- ▶ Have read and understood the safety guidelines given in this description
- ▶ Have a good knowledge of the generic and specialist standards applicable to the specific application.

3.2.2 Warranty and liability

All claims to warranty and liability will be rendered invalid if:

- ▶ The product was used contrary to the purpose for which it is intended
- ▶ Damage can be attributed to not having followed the guidelines in the manual
- ▶ Operating personnel are not suitably qualified
- ▶ Any type of modification has been made (e.g. exchanging components on the PCB boards, soldering work etc.).

3.2.3 Disposal

- ▶ In safety-related applications, please comply with the mission time t_M in the safety-related characteristic data.
- ▶ When decommissioning, please comply with local regulations regarding the disposal of electronic devices (e.g. Electrical and Electronic Equipment Act).

4.1 Module features

4.1.1 Functions

Module supply

- ▶ The module supply provides the module with voltage.

Periphery supply

- ▶ The module switches the periphery supply from the module bus to the base module terminals.
- ▶ The periphery supply is used to supply or provide test pulses to the input devices.

Inputs

- ▶ The input status is signalled to the head module via the module bus.
- ▶ Test pulses can be used to check the inputs for shorts across contacts and correct functionality.
- ▶ The inputs have input filters.

Test pulse outputs

- ▶ 2 test pulse outputs that use different test pulses (test pulse 0, test pulse 1)
- ▶ Short circuit-proof
- ▶ Current limitation
- ▶ Test pulses can be switched on or off.
- ▶ Test pulses are switched off in the default setting.
- ▶ When test pulses are switched off, the periphery supply is constantly available at the outputs.

Detection of shorts across contacts

- ▶ The test pulses are used to detect shorts between inputs. Shorts between inputs are detected when
 - the test pulses are different (test pulse 0, test pulse 1) or when
 - the test pulses originate from other modules on a PSSu system.
- ▶ Shorts between inputs of the same module with the same test pulses will not be detected.

Signal detection at the inputs

- ▶ A signal (“0” signal or “1” signal) is always ignored if it is present for less than the minimum processing time (see Technical details).
- ▶ A signal is always detected and transmitted to the process image (PII) if it is present for longer than the maximum processing time plus the scan time of the module bus ($t_2 + t_3$, see diagram and Technical details).

4.1 Module features

Timing diagram

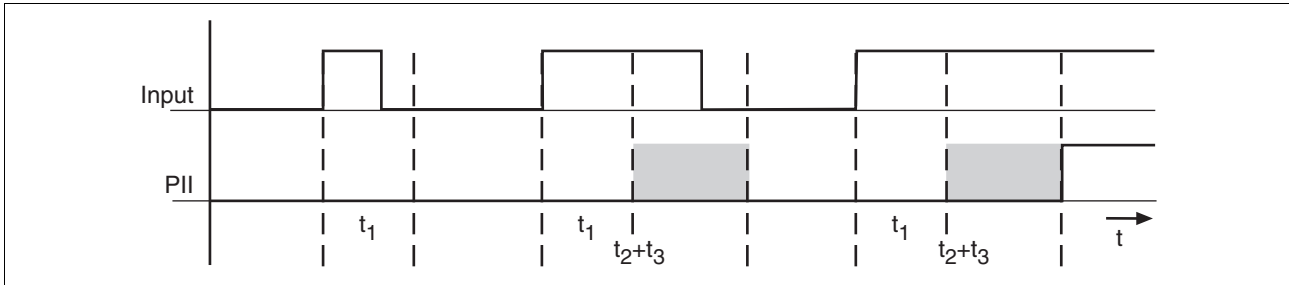

- ▶ Input: Signal at the input
- ▶ PII: Status of process image (PII)
- ▶ t_1 Minimum processing time (see Technical details)
- ▶ t_2 Maximum processing time (see Technical details)
- ▶ t_3 Scan time of module bus

Shaded area: Status of process image (PII) undefined.

4.1.2 Integrated protection mechanisms

When the PSSu E F PS1(-T) is used to supply the system, the module supply is buffered for 20 ms if the supply voltage is interrupted.

- ▶ Test pulse signals are always buffered for 20 ms.

The module provides the following diagnostic data:

- ▶ Start-up error
- ▶ Configuration error
- ▶ FS communication error
- ▶ Bus termination error
- ▶ Temperature error: Too warm
- ▶ Test pulse error
- ▶ Input error

4.1.3 Reaction times

Information on the reaction times of the inputs can be found in the PSSuniversal System Description.

4.2 Configuration

4.2.1 PSSu assignment in system environment A

Functions for the FS inputs of a PSSu are defined in the PSSuniversal Configurator on the PSS WIN-PRO system software:

- ▶ Read access through the standard bus system (configured per module):
“R” configuration
- ▶ Allocation of a test pulse output to an input (configured per input)
- ▶ Optimisation of ST process image by combining adjacent bits of the same type.
“**” configuration



INFORMATION

The PSSuniversal Configurator on the PSS WIN-PRO system software must be used to define the I/O-Groups to which FS inputs and outputs belong (SafetyBUS p). The PSSu can be divided into sections A and B for this purpose. All the FS inputs on a PSSu always belong to section B. Section A and section B on a PSSu may belong to different I/O-Groups.

Further information on configuration is available in the PSSuniversal Configurator's online help.

4.2.1.1 Addresses in the process image

The module occupies 4 consecutive bit addresses in the process image. The process image in which the inputs are shown depends on the configuration.

Configuration	SafetyBUS p	Standard bus system	
	FS-PII	ST-PII	ST-PIO
None	4 Bit	- - -	- - -
Read ST (“R”)	(e.g.: 32.00 ... 32.03)	4 Bit	- - -

4 Function description

4.2 Configuration

4.2.2 PSSu assignment in system environment B

Data access is via pre-defined I/O data types:

I/O data name	I/O data type	I/O data element	Meaning
I0(11), I1(21), I2(14), I3(24)	FS_I_DI	Data: SAFEBOOL	Input data I0 ... I3

5.1 General installation guidelines

Please also refer to the PSSuniversal Installation Manual.



CAUTION!

Damage due to electrostatic discharge!

Electrostatic discharge can damage components. Ensure against discharge before touching the product, e.g. by touching an earthed, conductive surface or by wearing an earthed arm-band.

5.1.1 Dimensions

Base modules with four connection levels:

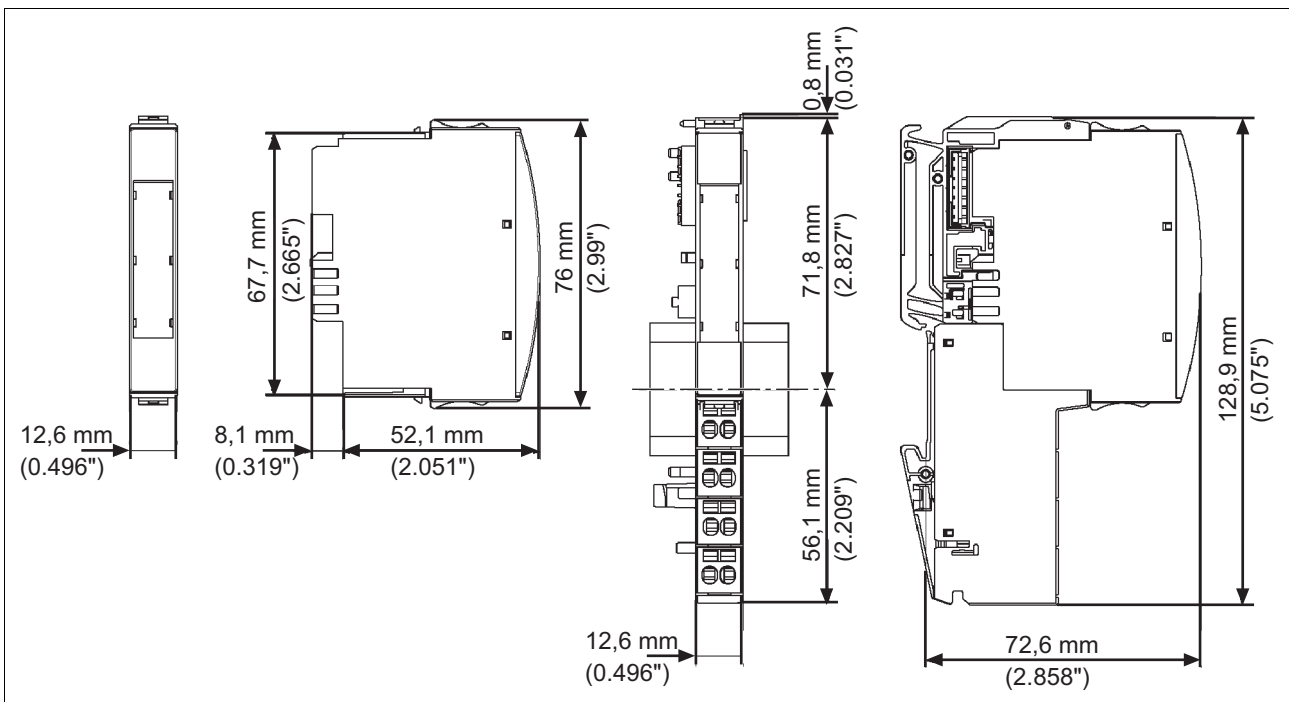

5.1 General installation guidelines

Base modules with six connection levels:

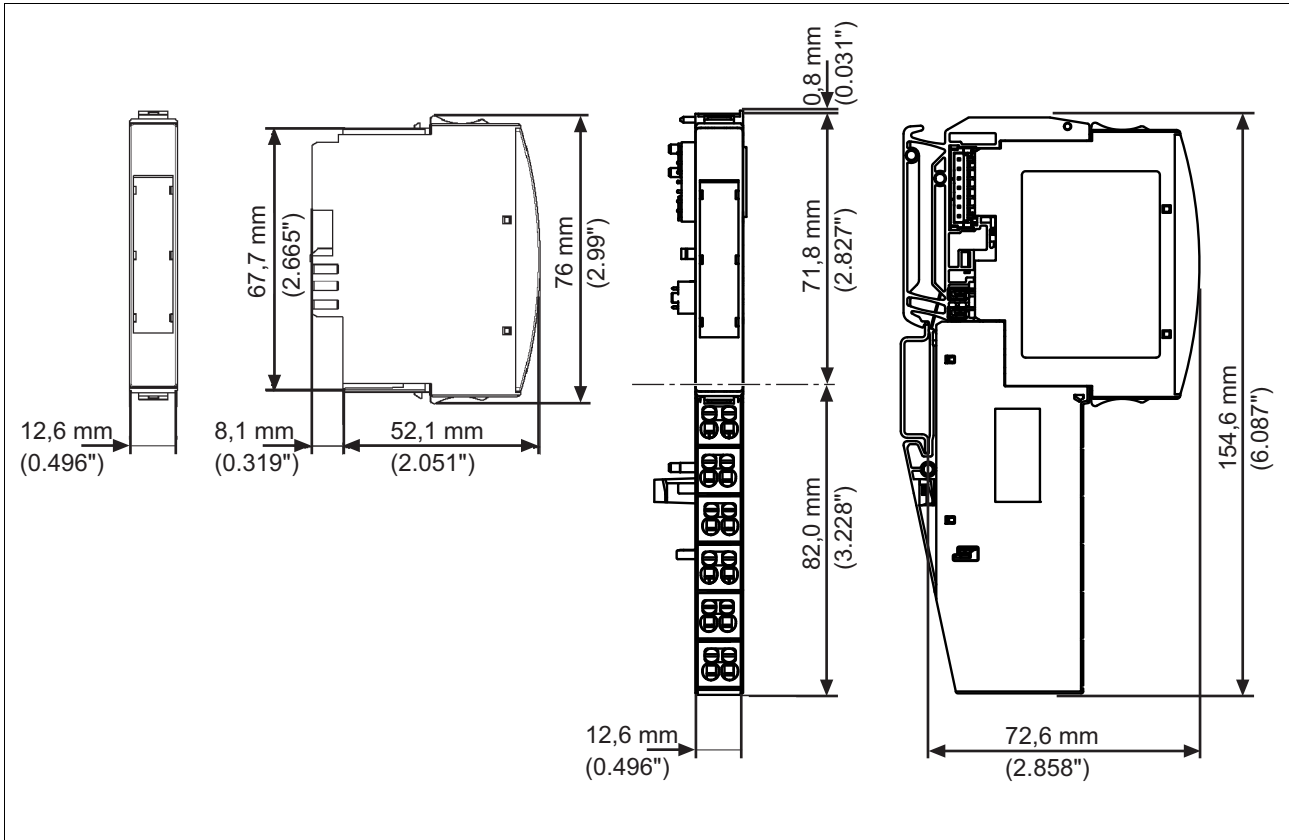

5.2 Installing the base module

Prerequisite:

- ▶ The head module must be installed.
- ▶ If the head module does not have an integrated power supply, a supply voltage module must be installed to the right of the head module.

Please note:

- ▶ For mechanical reasons it is not possible to mix base modules with screw terminals and base modules with cage clamp terminals.
- ▶ All contacts should be protected from contamination.
- ▶ The mechanics of the base modules are designed for 50 plug in/out cycles.

Procedure:

- ▶ We recommend that you wire up the base modules before inserting the electronic modules.
- ▶ Slot the groove on the base module on to the mounting rail from below [1].
- ▶ Push the base module back [2] until you hear it lock into position.
- ▶ On the mounting rail, slide the base module to the left until you hear the two lateral mounting hooks on the adjacent module lock into position [3].

Schematic representation:

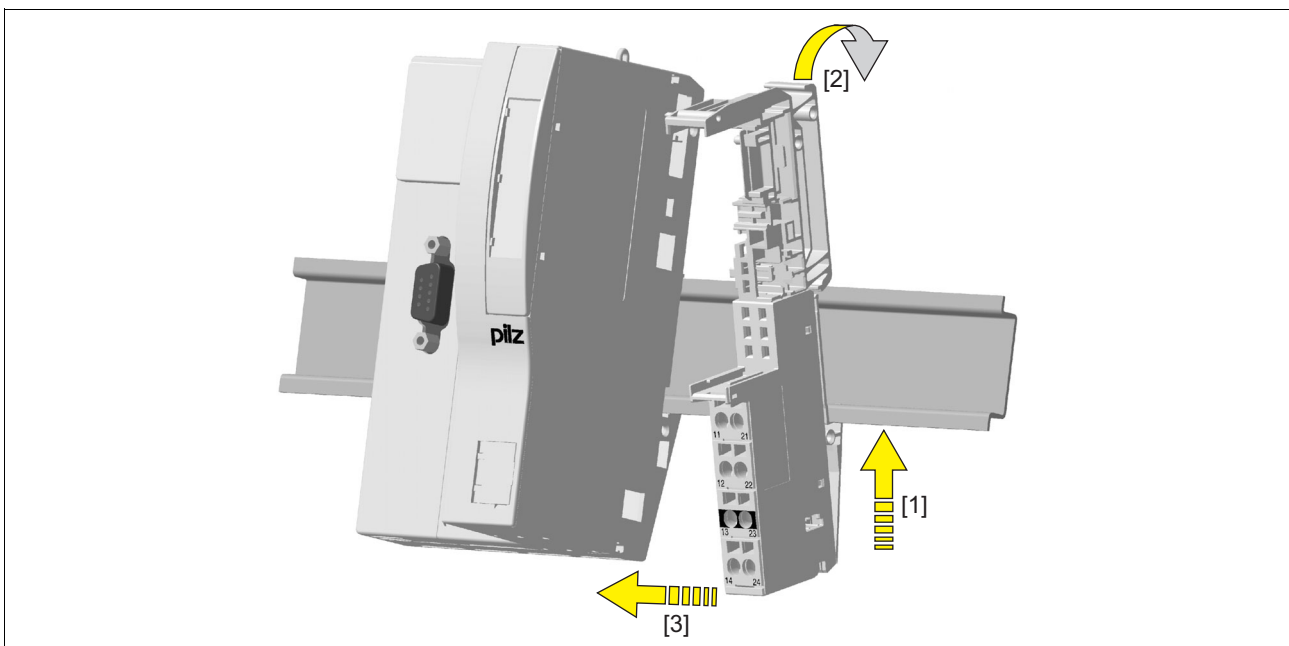

5.3 Inserting and removing an electronic module

Please note:

- ▶ Only insert on to base modules that are already installed.
- ▶ Preferably these base modules should be ready wired.
- ▶ Electronic modules with outputs may only be inserted and removed when the load is switched off. Unforeseeable error reactions may be triggered if modules are inserted and removed under load.
- ▶ When an electronic module is plugged into a base module for the first time, one part of the coding element remains on the electronic module, while its counterpart is fixed on to the base module. This is how the base module is coded.
- ▶ The mechanics of the electronic modules are designed for 50 plug in/out cycles.

5.3.1 Inserting an electronic module

Procedure:

- ▶ The electronic module must audibly lock into position [1].
- ▶ Mark the electronic module using the labelling strips [2].

Schematic representation:

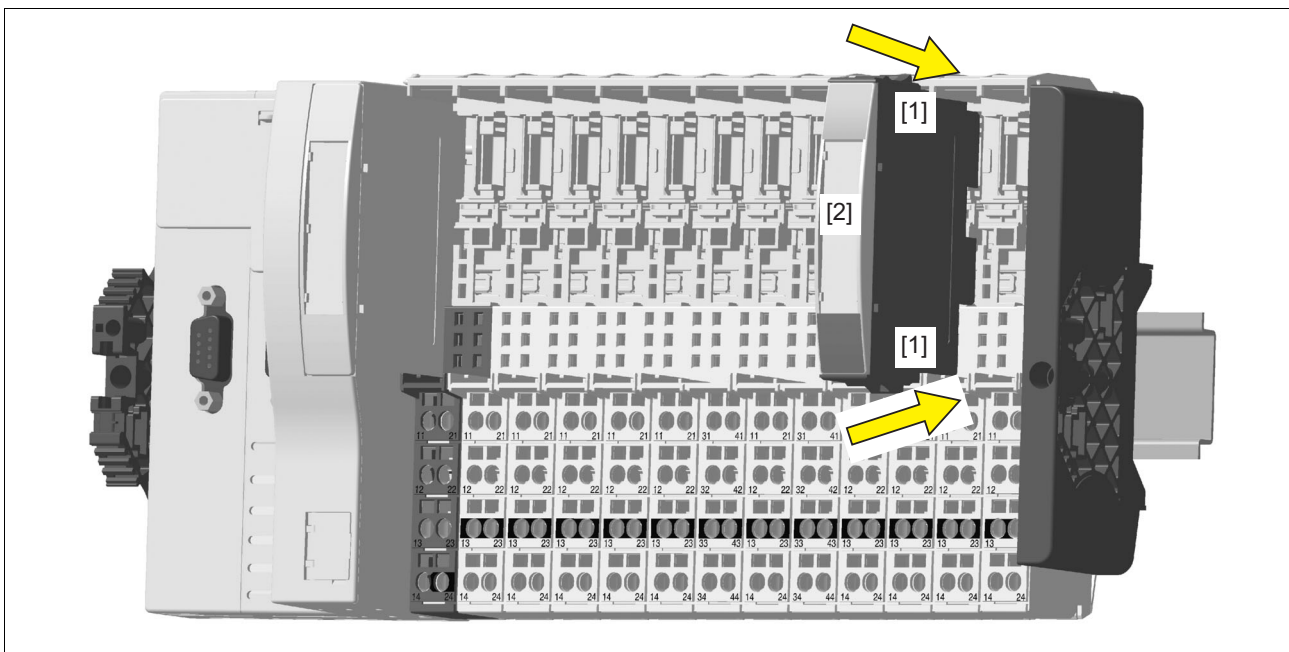

5.3 Inserting and removing an electronic module

5.3.2 Removing an electronic module

Procedure:

- ▶ Press the locking mechanisms [1] together simultaneously.
- ▶ Pull out the electronic module [2].

Schematic representation:

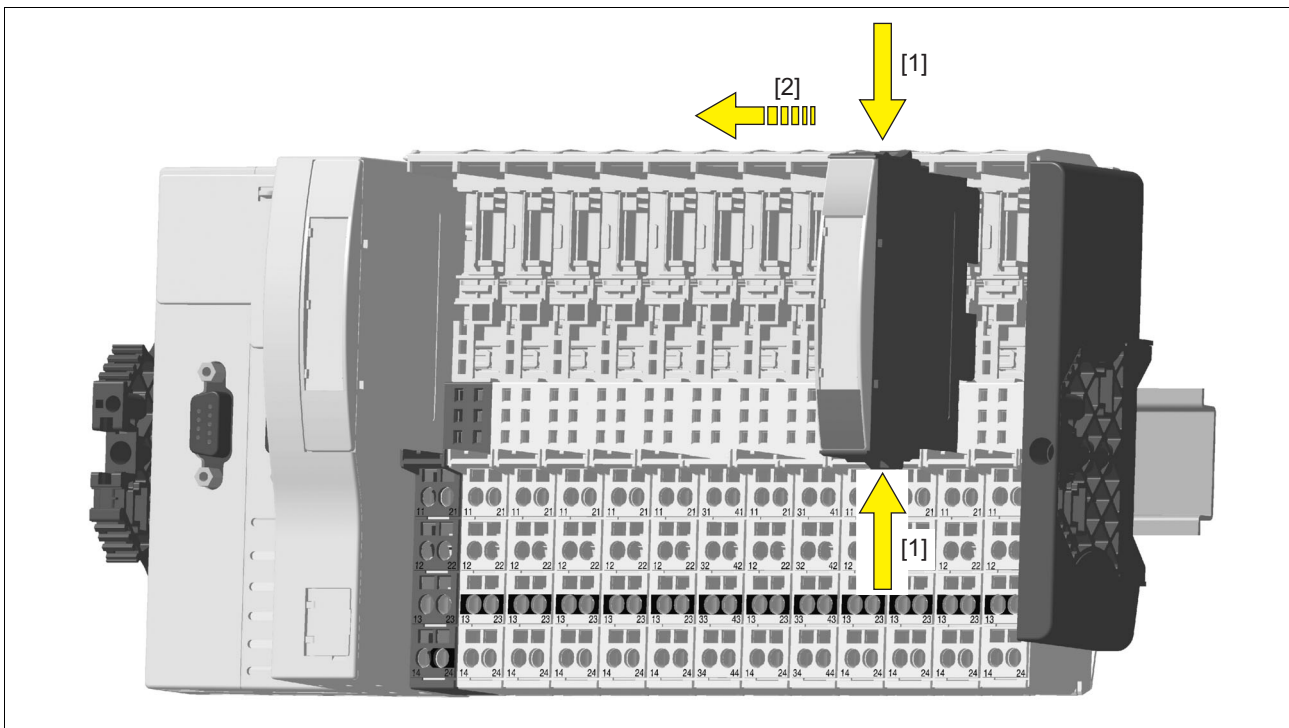

5.3 Inserting and removing an electronic module

5.3.3 Changing an electronic module during operation

The electronic module can be hot swapped. The configuration data is retained when a module is swapped.

Effects:

- ▶ System environment A:
 - In the event of a potential FS communication error, the FS section of the PSSu system and all relevant I/O-Groups (SafetyBUS p) switch to a STOP condition.
- ▶ System environment B:
 - While the module is disconnected, the default values of the input signals/input values are used (Valid-Bits = FALSE).
 - Once the module is reconnected, it is reactivated automatically.

6.1 General wiring guidelines

Please note:

- ▶ Appropriate wiring must be used to exclude short circuits between the test pulse outputs and the corresponding input!
- ▶ Appropriate wiring must be used to exclude short circuits between the inputs or to a supply line!
- ▶ The cable runs for the test pulses may be max. 200 m.
- ▶ Signal lines do not have to be shielded.
- ▶ Use copper wiring.

6.1.1 Mechanical connection of the base modules

Procedure:

- ▶ Use a flat blade screwdriver (DIN 5264-A)!

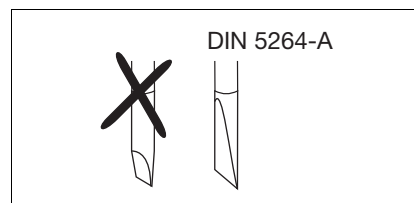

- ▶ Strip the wire back 8 mm.
- ▶ If necessary, label the connection level with a colour marker [3].
- ▶ Base module with screw terminals:
 - Use a screwdriver to loosen the screw on the screw terminal [1]
 - Insert the stripped cable into the round fixing hole [2], as far as it will go.
 - Tighten up the screw on the screw terminal.
 - Check that the cable is firmly seated.
- ▶ Base module with cage clamp terminals:
 - Insert the screwdriver [4] into the square hole [1].
 - Insert the stripped cable into the round fixing hole [2], as far as it will go [5].
 - Pull out the screwdriver [6].
 - Check that the cable is firmly seated.

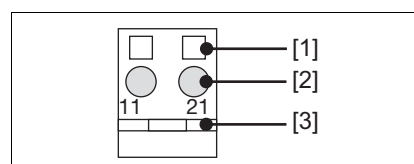

6.1 General wiring guidelines

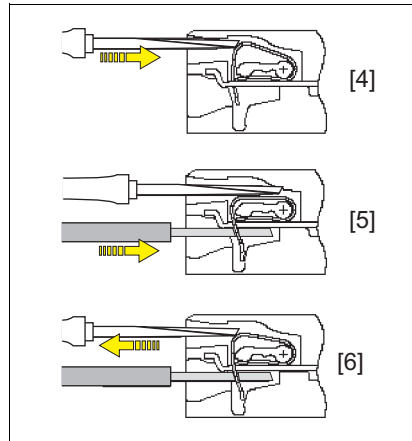

Please note:

- ▶ The minimum cable cross section for field connection terminals on the base modules is 0.14 mm² (AWG26)
- ▶ The maximum cable cross section for field connection terminals is:
 - Digital inputs: 1.5 mm² (AWG16)
 - Digital outputs: 2.0 mm² (AWG14)
 - Inputs/outputs on the counter modules: 1.5 mm² (AWG16)
 - Analogue inputs/outputs: 1.5 mm² (AWG16)
 - Communication cables: 1.5 mm² (AWG16)
 - Test pulse outputs: 1.5 mm² (AWG16)
 - Power supply: 2.5 mm² (AWG12)
 - Functional earth: 2.5 mm² (AWG12)
- ▶ On base modules with screw terminals:
 - If you use a multi-strand cable to connect the I/Os, it is recommended that you use ferrules conforming to Parts 1 and 2 of DIN 46228, 0.14 ... 1.5 mm², Form A or C, although this is not essential. To crimp the ferrules you can use crimp pliers (crimp form A or C) conforming to EN 60947-1, such as the PZ 1.5 or PZ 6.5 from Weidmüller, for example.
 - Maximum torque setting: 0.8 Nm
- ▶ Use copper wiring.

6.2 Terminal configuration

Base module	Terminal configuration	
Screw terminals: PSSu BP 1/8S PSSu BP 1/8S-T	Without C-rail: 11: Input I0 21: Input I1 12-22: Test pulse output T0 or +24 V output (periphery supply, 12-22 linked within the base module) 13-23: Test pulse output T1 or +24 V output (periphery supply, 13-23 linked within the base module) 14: Input I2 24: Input I3	
Screw terminals: PSSu BP-C1 1/12S PSSu BP-C1 1/12S-T	With C-rail: 11: Input I0 21: Input I1 12-22: Test pulse output T0 or +24 V output (periphery supply, 12-22 linked within the base module) 13-23: C-rail supply (13-23-16-26 linked within the base module) 14: Input I2 24: Input I3 15-25: Test pulse output T1 or +24 V output (periphery supply, 15-25 linked within the base module) 16-26: C-rail supply (13-23-16-26 linked within the base module)	

6.3 Connecting the module

Input circuit	Single-channel input device	Dual-channel input device
Without test pulses (unchecked)		
Without test pulses (unchecked) Input device with homogenous channels		
Without test pulses (unchecked) Input device with diverse channels		

6.3 Connecting the module

<p>With test pulses (checked)</p>		
<p>With test pulses (checked) Input device with homogenous channels</p>		
<p>With test pulses (checked) Input device with homogenous channels</p>		

6.3 Connecting the module

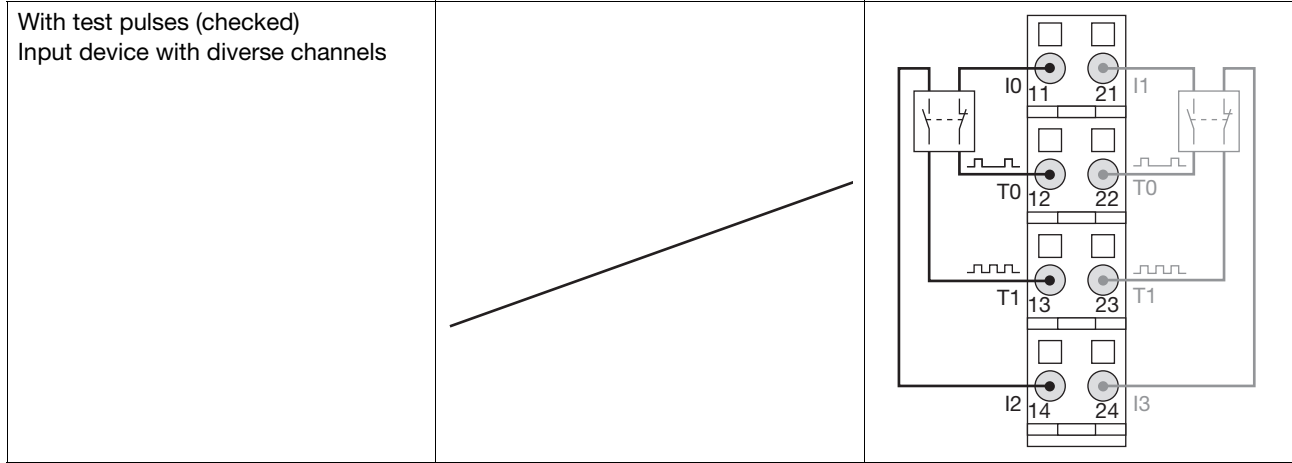

7.1 Messages

A module error is displayed via the "Err" LED (see section entitled "Display elements"), signalled to the head module and then entered in the head module's

- ▶ Error stack, with PSSu in system environment A
- ▶ Diagnostic log, with PSSu in system environment B.

The module can detect the following errors:

Module error	Explanation	Remedy
Start-up error	Error as the PSSu system starts up	Change faulty module.
Configuration error	Incorrect module type configured.	The configured hardware registry does not match the actual hardware registry.
FS communication error	Error during FS communication	Change faulty module.
Bus termination error	There is no terminating plate or there is a bad contact with the module bus.	Install a terminating plate with integrated end bracket or insert the base modules together correctly.
Temperature error: too warm	Ambient temperature too high: Error stack entry/diagnostic log entry	Ensure there is sufficient ventilation in the control cabinet or prevent overload.
Error in the feedback loop	FS input detects an error in the feedback loop or FS input is defective.	Check FS input, check the configuration of the feedback loop, check the signals, or check the wiring and contacts.
Input error	Error during the cyclical input test. Possible cause: Input defective.	Change faulty module.
Test pulse error	Possible causes: Short circuit between a test pulse and a supply voltage, or a defective module.	Rectify the short circuit or change the faulty module.

7.2 Display elements

Key:

	LED on
	LED off

7.2.1 Display elements for module diagnostics

The module has an LED for displaying module errors ("Err" LED).

	LED			Key
	Name	Colour	Status	
	Err	---		No error
	red		Module error	

7.2 Display elements

7.2.2 Display elements for input status

Each input is assigned an LED for displaying the input status (LEDs “11”, “21”, “14” and “24”).

	LED			Key		
	Description	Colour	Status	Signal	Input	Terminal
	11	---	●	0 signal	I0 (Input 1)	11
		green	☀	1 signal		
	21	---	●	0 signal	I1 (Input 2)	14
		green	☀	1 signal		
	14	---	●	0 signal	I2 (Input 3)	21
		green	☀	1 signal		
	24	---	●	0 signal	I3 (Input 4)	24
		green	☀	1 signal		

8.1 Technical details

Technical details	
Application range	Failsafe
Maximum achievable category in accordance with EN 954-1	4
Maximum achievable SIL value	SIL3
Module's device code	0A00h
Number of FS input bits	4
Support in system environment A	yes base type, T-type no R-type
from FS firmware version for other head modules	4 base type, T-type
from FS firmware version PSSu H F PN	1 base type, T-type
Support in system environment B	yes
from head module FS firmware version	1.0.0 base type, T-type 1.5.0 R-type
Electrical data	
Internal supply voltage (module supply)	
Supply voltage range of module supply	4.8 - 5.4 V
Module's current consumption	23 mA
Module's power consumption	0.12 W
Periphery's supply voltage (periphery supply)	
Voltage range	16.8 - 30.0 V
Module's current consumption with no load	8 mA
Module's power consumption with no load	0.19 W
Max. power dissipation of the module	1.50 W
Inputs	
Number	4
Input voltage	24 V DC
Input current	2.6 - 7.8 mA
Min. threshold voltage when signal changes from "1" to "0"	9.0 V
Max. threshold voltage when signal changes from "0" to "1"	10.0 V
Potential isolation between input and voltage for the internal module bus	yes
Number of test pulse outputs	2
Number of outputs that can be configured as test pulses	2
Max. output current at "1" signal	0.25 A
Short circuit-proof	yes
Max. cable runs between test pulse output and input	200 m
Standard for voltage interruptions	EN61131-2, EN61496-1
Times	
Max. processing time for input when signal changes from "1" to "0"	1.000 ms
Max. processing time for input when signal changes from "0" to "1"	1.000 ms
Min. processing time for input when signal changes from "1" to "0"	0.50 ms
Min. processing time for input when signal changes from "0" to "1"	0.50 ms

8.1 Technical details

Environmental data	
Climatic suitability	EN 50125-1, EN 50125-3, EN 60068-2-14, EN 60068-2-1, EN 60068-2-2, EN 60068-2-30, EN 60068-2-78
Ambient temperature in accordance with EN 60068-2-14 base type, T-type	-40 - 70 °C T-type 0 - 60 °C base type
Storage temperature in accordance with EN 60068-2-1/-2	-25 - 70 °C base type -40 - 70 °C T-type
Climatic suitability in accordance with EN 60068-2-30, EN 60068-2-78	93 % r. h. at 40 °C base type, T-type
Condensation	yes T-type no base type
Max. operating height above sea level	2000 m base type 5000 m T-type
EMC	EN 61000-4-2, EN 61000-4-3, EN 61000-4-4, EN 61000-4-5, EN 61000-4-6, EN 61000-6-2, EN 61000-6-4
Vibration to EN 60068-2-6 base type, T-type	
Frequency	10 - 150 Hz base type, T-type 10 - 55 Hz R-type
Max. acceleration	1g base type, T-type
Broadband noise in accordance with EN 60068-2-64 T-type	
Frequency	5 - 500 Hz T-type
Max. acceleration	1.9grms T-type
Shock stress	
EN 60068-2-27 base type, T-type	15g base type, T-type 11 ms base type, T-type
EN 60068-2-29 base type, T-type	10g base type, T-type 16 ms base type, T-type
Protection type in accordance with EN 60529 base type, T-type	
Mounting (e.g. cabinet)	IP54 base type, T-type
Housing	IP20 base type, T-type
Terminals	IP20 base type, T-type
Airgap creepage in accordance with EN 60664-1 base type, T-type	
Overvoltage category	II base type, T-type
Pollution degree	2 base type, T-type
Environmental data for railway applications	
Installation location in accordance with EN 50125-3 R-type	Track area (1m – 3m) R-type
Installation location in accordance with EN 61373 R-type	Category 1, Class A + B R-type
Climatic suitability	50125-1, 50125-3, 50155
Max. operating height above sea level	2,000 m R-type
Ambient temperature in accordance with EN 50155 R-type	-40 ... +70 °C R-type
Ambient temperature in accordance with EN 50125-1 R-type, EN 50125-3 R-type	-40 ... +70 °C R-type
Shock stress EN 50125-3 R-type	2 g R-type 11 ms R-type
Vibration to 50125-3 R-type	0.23 g R-type 5 ... 2,000 Hz R-type

8.1 Technical details

Environmental data for railway applications

Shock stress EN 61373 R-type	5 g R-type 30 ms R-type
Broadband noise in accordance with EN 61373 R-type	
Max. acceleration	0.79 g RMS R-type
Frequency	5 ... 150 Hz R-type
Protection type in accordance with EN 60529 R-type	
Mounting (e.g. cabinet)	IP51 R-type
Housing	IP20 R-type
Terminals	IP20 R-type
Airgap creepage in accordance with EN 50124-1 R-type	
Overvoltage category	OV2 R-type
Pollution degree	PD1 R-type
Supply interruptions in accordance with EN 50155 R-type	S2, C1, C2 R-type

Mechanical data

Housing material	
Front	PC
Bottom	PC
Coding	PA
Dimensions	
Height	76.0 mm
Width	12.6 mm
Depth	60.2 mm
Weight	44 g base type 45 g R-type, T-type
Mechanical coding	
Type	D
Colour	yellow

Safety characteristic data

Unit	Operating mode	EN ISO 13849-1: 2006 PL	EN 954-1 Category	EN IEC 62061 SIL CL	PFH [1/h]	EN ISO 13849-1: 2006 T _M [year]
digital inputs	single-channel	PL d (Cat. 2)	Cat. 2	SIL CL 2	9.10E-09	20
digital inputs	dual-channel	PL e (Cat. 3)	Cat. 3	SIL CL 3	3.10E-09	20
digital inputs	light beam device	PL e (Cat. 4)	Cat. 4	SIL CL 3	2.91E-09	20

All the units used within a safety function must be considered when calculating the safety characteristic data.

The standards current on **2009-10** apply.

8.2 Order reference

Order reference	
Description	Order no.
PSSu E F 4DI (Electronic module, base type)	312 200
PSSu E F 4DI-T (Electronic module, T-type)	314 200
PSSu E F 4DI-R (Electronic module, R-type)	315 200
Base Modules	Order no.
PSSu BP 1/8S (Base module without C-rail with screw terminals)	312 600
PSSu BP 1/8S-T (Base module without C-rail with screw terminals, T-type)	314 600
PSSu BP 1/8C (Base module without C-rail with cage clamp terminals)	312 601
PSSu BP 1/8C-T (Base module without C-rail with cage clamp terminals, T-type)	314 601
PSSu BP 1/12S (Base module without C-rail with screw terminals)	312 618
PSSu BP 1/12S-T (Base module without C-rail with screw terminals, T-type)	314 618
PSSu BP 1/12C (Base module without C-rail with cage clamp terminals)	312 619
PSSu BP 1/12C-T (Base module without C-rail with cage clamp terminals, T-type)	314 619
PSSu BP-C1 1/12S (Base module with C-rail and screw terminals)	312 622
PSSu BP-C1 1/12S-T (Base module with C-rail and screw terminals, T-type)	314 622
PSSu BP-C1 1/12C (Base module with C-rail and cage clamp terminals)	312 623
PSSu BP-C1 1/12C-T (Base module with C-rail and cage clamp terminals, T-type)	314 623