

# Class 150 Ductile Iron Body Gate Valves

Raised face flanges • bolted bonnet • outside screw and yoke • solid wedge • bronze trim

**285 PSI/19.7 bar non-shock cold working pressure to -20°F to 100°F/-29°C to 38°C**

**Maximum working temperature 650°F/343°C at 125 PSI/8.6 bar**

**150 PSI/10.3 bar saturated steam to 366°F/186°C**

CONFORMS TO MSS SP-128

## MATERIAL LIST

PART	SPECIFICATION
1. Handwheel Nut	Brass ASTM B584 C84400
2. Identification Plate	Aluminum
3. Handwheel	Fabricated Steel
4. Yoke Bushing	Brass ASTM B584 C84400
5. Split Yoke Bolt	Steel ASTM A307/SAE J429
6. Split Yoke Bolt Nut	Steel ASTM A563
7. Yoke	Ductile Iron ASTM A536
8. Eye Bolt Nut	Brass ASTM F467
9. Gland Follower	Ductile Iron ASTM A536
10. Yoke Bolt	Steel ASTM A307/SAE J429
11. Yoke Bolt Nut	Steel ASTM A563
12. Gland Follower Eye Bolt	Steel ASTM A307/SAE J429
13. Packing Gland	Brass ASTM B584 C84400
14. Packing	PTFE Braided
15. Backseat Bushing	Brass ASTM B371
16. Bonnet	Ductile Iron ASTM A395
17. Stem	Brass ASTM B371
18. Bonnet Bolt	Steel ASTM A307/SAE J429
19. Bonnet Bolt Nut	Steel ASTM A563
20. Bonnet Gasket	Synthetic Fibers
21. Body	Ductile Iron ASTM A395
22. Wedge	Ductile Iron ASTM A395
23. <sup>1</sup> Seat Ring	Brass ASTM B584 C84400
24. Wedge Ring	Brass ASTM B584 C84400
25. Swing Nut	Steel ASTM A563
26. Swing Bolt	Steel ASTM A307/SAE J429
27. Grease Fitting	Alemite 1743B (not shown)
28. Stem Collar	Brass ASTM B371 (not shown) C69430/C69400
29. Wedge Pin	Brass ASTM B371 (not shown) C69430/C69400
30. Wedge Nut	Brass ASTM B584 (not shown) C69430/C69400

<sup>1</sup>Lugs may be removed at customer's request – POA.

## DIMENSIONS—WEIGHTS—QUANTITIES

Size	Dimensions										Turns to Open	Weight		
	A		B		C		D		E			Lbs.	Kg.	
In.	mm.	In.	mm.	In.	mm.	In.	mm.	In.	mm.	In.	mm.			
14	350	15.00	381	65.50	1664	24.00	610	21.00	533	1.38	35	29.38	892	405
16	400	16.00	406	74.50	1892	24.00	610	23.50	597	1.44	37	33.50	1253	568
18	450	17.00	432	82.50	2096	24.00	610	25.00	635	1.56	40	37.63	1592	722
20	500	18.00	457	91.00	2311	30.00	762	27.50	699	1.69	43	41.88	2008	911
24	600	20.00	508	107.50	2731	30.00	762	32.00	813	1.88	48	50.06	2907	1318



**F-637-31**  
Flanged-Raised Face

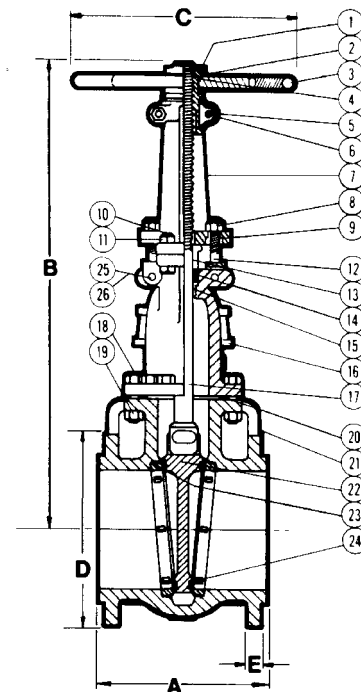

**F-637-31**  
Flg x Flg

**FREEZING WEATHER PRECAUTION:** Subsequent to testing a piping system, valves should be left in an open position to allow complete drainage.

◆ For detailed Operating Pressure, refer to Pressure Temperature Chart on page 114.

VISIT [WWW.NIBCO.COM](http://WWW.NIBCO.COM) FOR CURRENT CHEM-GUIDE AND GALVANIC POTENTIAL IN PIPING SYSTEMS INFORMATION.

Visit our website for the most current information.